

BATTERIEDATENBLATT

**Panther Motorrad
Premium 50612**

Artikelnummer: MB.5061277
 ETN-Nummer: 506 0 12 004
 Japan-Nummer: 12N5.5A-3B

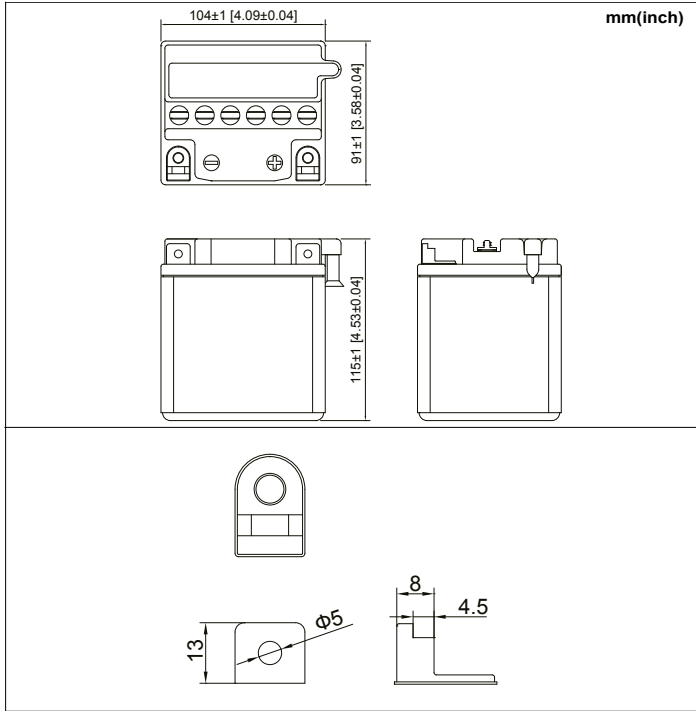

(V)
FOR 12V
BATTERY

Discharge Time VS. Discharge Current(25 °C)

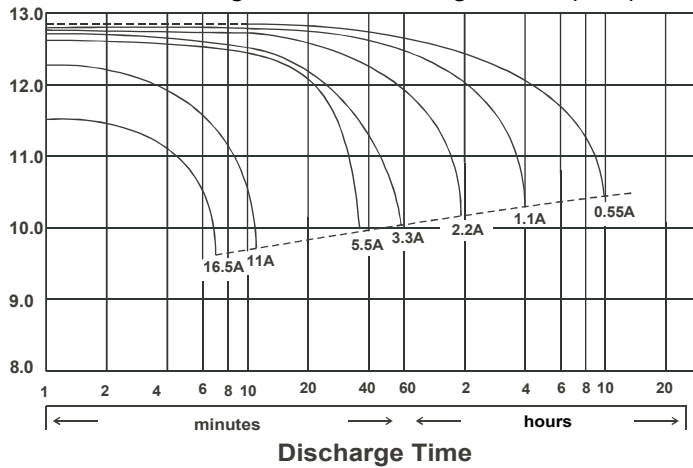

Schaltung 0

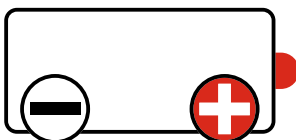

Anschlusspole Y6

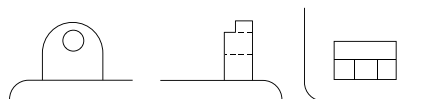

Technologie	RF - rüttelfest
Separator Typ	Reinforcing fiber+Glass Fiber
Box-Material	Polypropylen (PP/PE)
Boxfarbe (Körper)	Weiß
Boxfarbe (Deckel)	Schwarz
Spannung	12 V
Kapazität	6 Ah
Kälteprüfstrom	40 A/EN
L x B x H (mm)	104 x 91 x 115
Schaltung	0
Abgaswinkel	Rechts
Anschlusspole	Y6
Gewicht	2.5 kg
Zustand	trocken vorgeladen
Inkl. Säurepack, Abgasschlauch und Schrauben.	

