

BATTERIEDATENBLATT

**Panther Motorrad
Premium 00612**

Artikelnummer: MB.0061277
ETN-Nummer: 006 0 12 003
Japan-Nummer: 6N6-3B-1

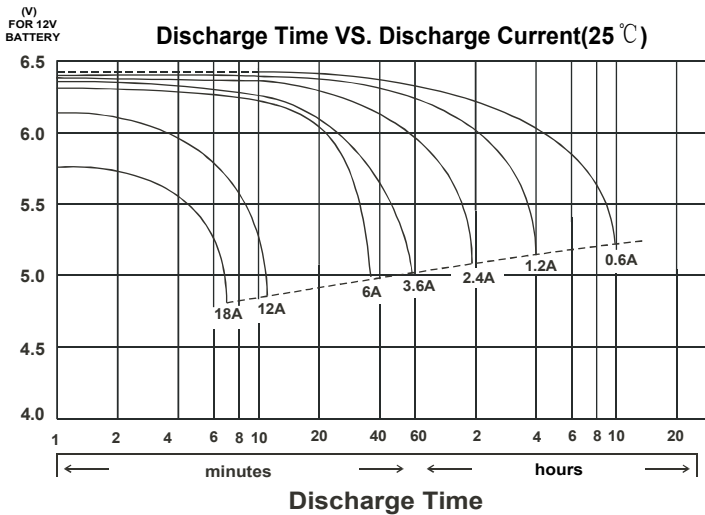
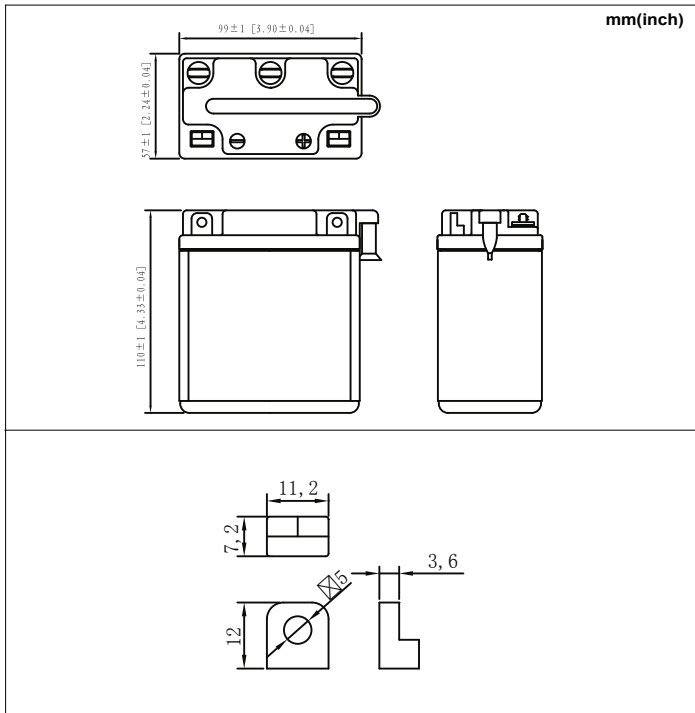

Technologie	RF - rüttelfest
Separator Typ	Reinforcing fiber+Glass Fiber
Box-Material	Polypropylen (PP/PE)
Boxfarbe (Körper)	Weiß
Boxfarbe (Deckel)	Schwarz
Spannung	6 V
Kapazität	6 Ah
Kälteprüfstrom	30 A/EN
L x B x H (mm)	100 x 58 x 112
Schaltung	0
Abgasswinkel	Rechts
Anschlusspole	Y6
Gewicht	1.3 kg
Zustand	trocken vorgeladen

Inkl. Säurepack, Abgasschlauch und Schrauben.

Schaltung 0

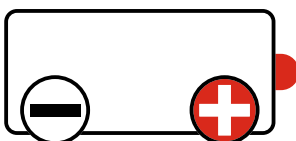

Anschlusspole Y6

