

Art. Nr.: **GB.12085**
Bezeichnung: **GB.12-085**

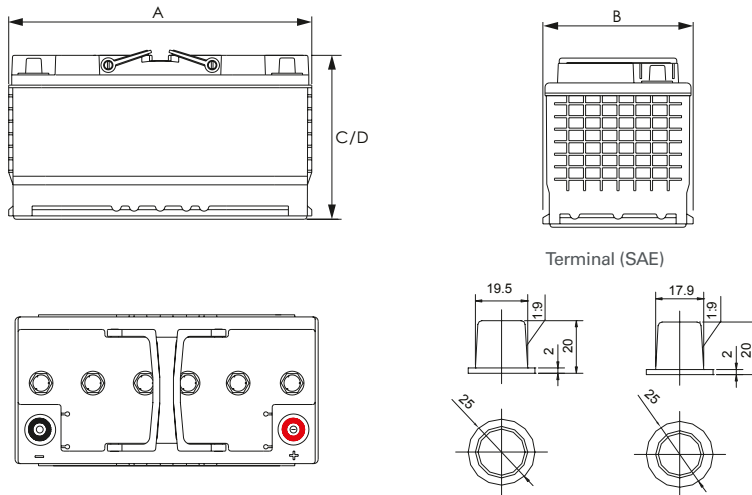

MECHANICAL SPECIFICATIONS

Industry Reference	49-L5	
Length (A)	13.9 in	353 mm
Width (B)	6.9 in	175 mm
Height (C)	7.5 in	190 mm
Total Height (D)	7.5 in	190 mm
Weight	51.7 lbs	23.5 kgs
Terminal	SAE	
Cell(s)	6	
Electrolyte	1.300 S.G.	Absorbed electrolyte, VRLA non-spillable

NOTE: There is a tolerance of +/-2%.

ELECTRICAL SPECIFICATIONS

Voltage	12 V	
Internal Resistance	5.00 mΩ	
Short Circuit (20°C 68°F)	-	
Self Discharge	Less than 3% per month (20°C 68°F)	
Cranking Amps**	-	-
Charge Temperature	Min: -10°C (14°F) Max: 50°C (122°F)	
Discharge Temperature***	Min: -40°C (-40°F) Max: 50°C (122°F)	
Storage	Min: -20°C (-4°F) Max: 60°C (140°F)	

**CRANKING AMPS: Cranking Amps data is provided as a reference only. Specific application sizing and life factors must be considered when using deep cycle product in a starting application.
***CAUTION: Extra considerations must be given to depths of discharge, operating voltages and currents when designing systems for use at maximum temperatures.

ELECTRICAL SPECIFICATIONS

Amp Hours (AH)				Minutes of Discharge	
100 HR	20 HR	10 HR	5 HR	@25A	@75A
85	80	75	64	122	36

Max Charge / Discharge Current	Peak (5 seconds)	Peak (10 seconds)	Max Continuous
Charge	1C20Hr	0.75C20Hr	0.25C20Hr
Discharge	10C20Hr	10C20Hr	0.5C20Hr

CHARGE RECOMMENDATION

Float (Stand-By) Use: Hold a constant voltage of 2.25vpc to 2.30vpc continuously. When held at this voltage, the battery will seek its own current level and maintain itself in a fully charged condition.

Cyclic Use: Limit initial currents to 0.25C20 amps. Charge until battery voltage reaches 2.40 to 2.45vpc. Hold at 2.40 to 2.45vpc until current drops to under 0.01C20 amps. Battery is fully charged under these conditions, and charger should be disconnected or switched to "float" voltage.

Temperature Coefficient: Adjust charging voltage to +/- 0.005vpc (C, 0.003vpc/F) from 25°C (77°F).

BENEFITS & FEATURES

Optimized lead calcium plates deliver high power density and consistent performance.

Special grid alloy and paste formula to reduce gassing and self-discharge.

Sealed valve regulated non-spillable Maintenance-free technology.

99% gas recombination for extended life in float or cyclic applications.

Multiple battery terminal options and carrying handles.

UL924 recognized flame arresting low pressure safety vents.

High impact reinforced polypropylene cases with flat top designs.

98% recyclable.

Classified as a non-spillable battery is not restricted for transportation by:

- Air (IATA/ICAO provision 67)
- Ground (STB, DOT-CFR-HMR49)
- Water (IMDG amendment 27)

HYDRO POLYMER

- Organic Capillary Separator Technology Fully Saturated with Bi-Polar Hydrophilic Polymer Electrolytes Deliver Extra Electrolyte Volume
- Resist Premature Dry-out and Prevents Thermal Runaway
- Maintains high Performance Characteristics Across Operational Life

CERTIFIED QUALITY

Discover® and its facilities and products are tested and certified to multiple standards:

- ISO, UL, CE, and QS standards
- ETTS Germany
- Euro Bat classification for Environmental Stewardship Standards

Designed in accordance with and published in compliance with applicable BCI, IEC and BS EN standards, including:

- IEC60896-21/22
- BS EN 60254-1:2005
- AS/NZS 4029.2:2000

