



**Panther**  
ABS LINE

## Antrieb & Beleuchtung

ART. NR.: **TRNAB06-160**

DIN-NR.: **91301**

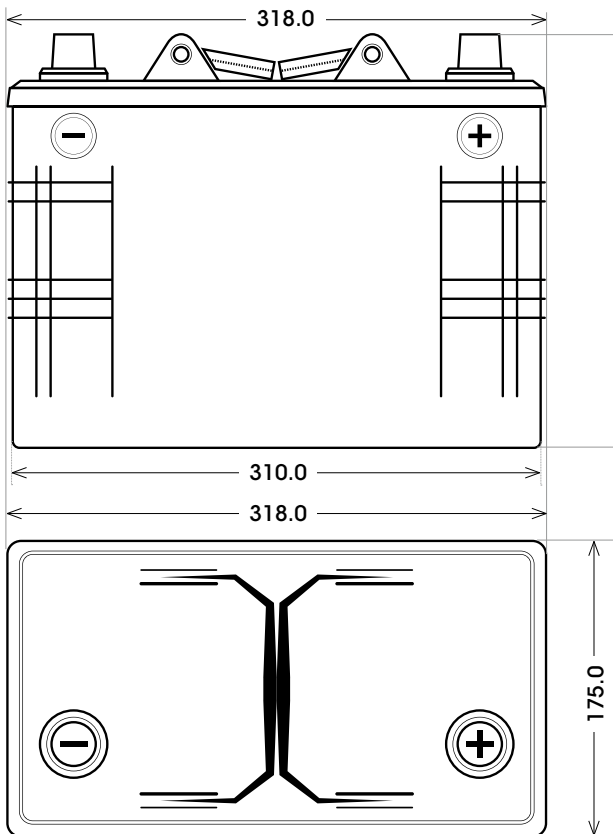

Technology	Pb/Ca
Application	Semi Traction
Brand	tracline
Box Type	98 Compact, PPCo
Lid Type	PPCo flat lid with C13 plugs, IHL (integrated handle to cover)
Electrolyte Density	1.28 ± 0.01 g/cm <sup>3</sup>
Water loss	VERY LOW
Separator	Polyethylene + GM (1.3 mm)
Number of cycles 50% DOD:	150 (according to EN 50342-1:2015)
Voltage	6 Volt
Capacity 100h	180 Ah
Capacity 20h	160 Ah
Capacity 5h	130 Ah
Size L x W x H	318 x 175 x 210 (mm)
Layout	0
Terminal	1
Bottom holder	B00
Weight	29,0 kg
Packaging	36 pieces/euro pallet
Shipment regulation:	- Normal for road transportation - Special condition 8 class hazard UN2794 for sea transportation

Bodenleiste B00

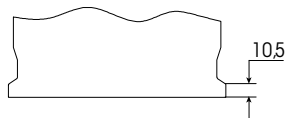

Schaltung 0

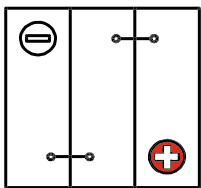

Anschlusspole 1

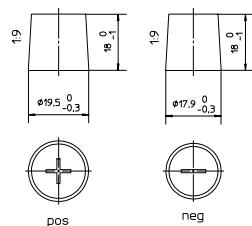

pos

neg

**tracline**





## Antrieb & Beleuchtung

ART. NR.: **TRNAB06-160**

DIN-NR.: **91301**

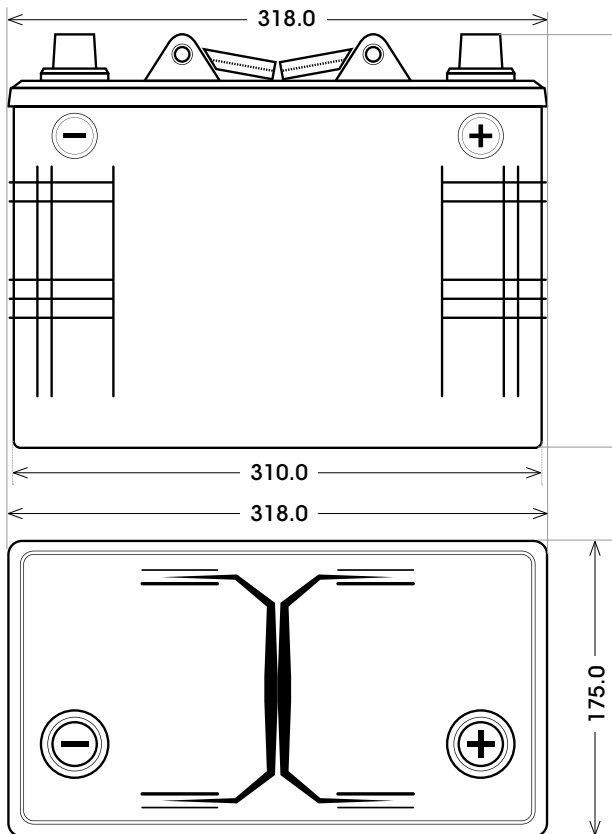

Technology	Pb/Ca
Application	Semi Traction
Brand	tracline
Box Type	98 Compact, PPCo
Lid Type	PPCo flat lid with C13 plugs, IHL (integrated handle to cover)
Electrolyte Density	1.28 ± 0.01 g/cm <sup>3</sup>
Water loss	VERY LOW
Separator	Polyethylene + GM (1.3 mm)
Number of cycles 50% DOD:	150 (according to EN 50342-1:2015)
Voltage	6 Volt
Capacity 100h	180 Ah
Capacity 20h	160 Ah
Capacity 5h	130 Ah
Size L x W x H	318 x 175 x 210 (mm)
Layout	0
Terminal	1
Bottom holder	B00
Weight	29,0 kg
Packaging	36 pieces/euro pallet
Shipment regulation:	- Normal for road transportation - Special condition 8 class hazard UN2794 for sea transportation

Bottom holder **B00**

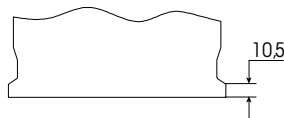

Terminal **1**

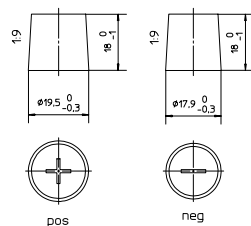

Layout **0**

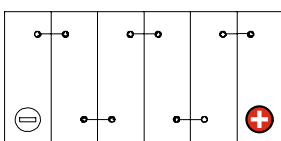

**tracline**

