

Art. Nr.: **SB.6004400**

Bezeichnung: **60044**

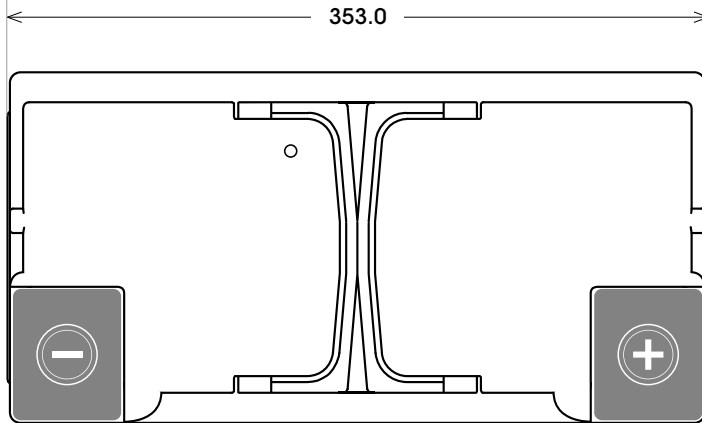
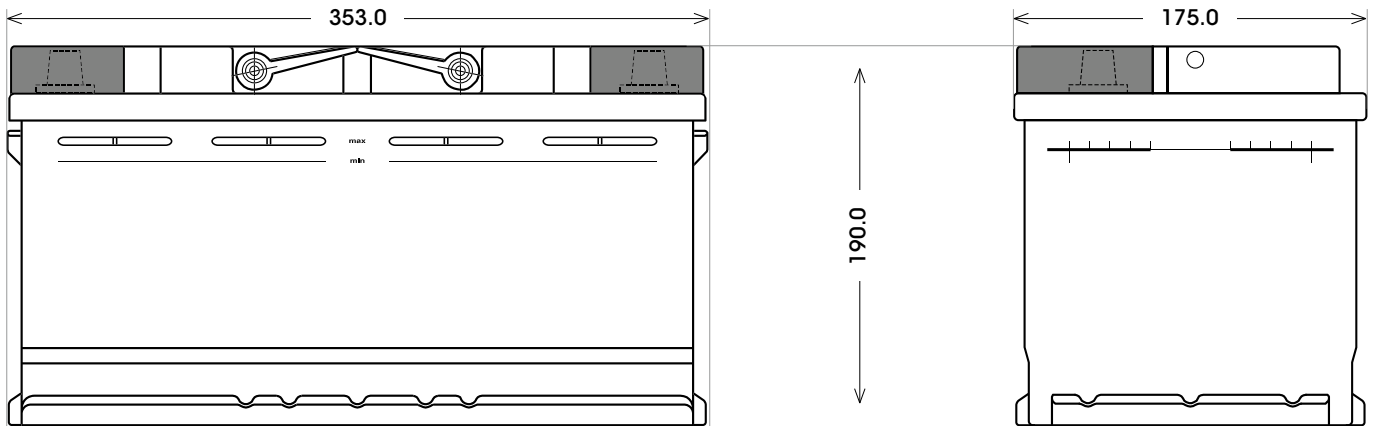

Technologie	Calcium-Calcium
Separator Typ	Envelope
Box-Material	Polypropylen
Boxfarbe	Schwarz
Spannung	12 V
Kapazität	100 Ah
Kälteprüfstrom	760 A/EN
L x B x H (mm)	353 x 175 x 190
Bodenleiste	B13
Schaltung	0
Anschlusspole	1
Gewicht	16.7 kg
Stück/Palette	48
Ausführung	trocken vorgeladen

Bodenleiste B13

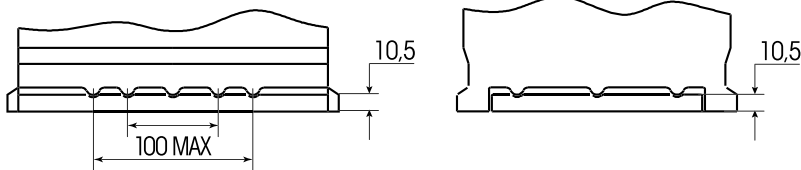

Schaltung 0

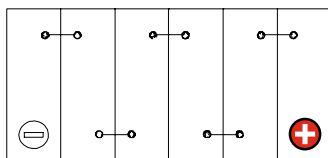

Anschlusspole 1

