

Art. Nr.: **SB.5702900**

Bezeichnung: **57029**

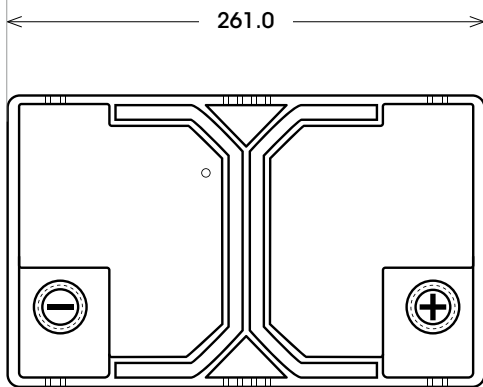
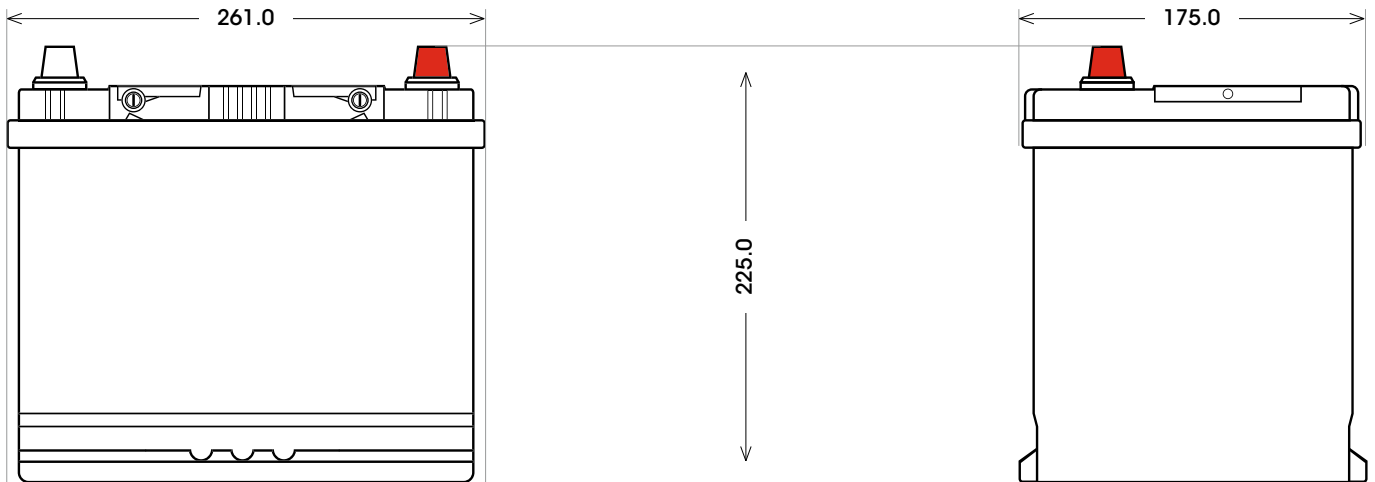

Technologie	Calcium-Calcium
Separator Typ	Envelope
Box-Material	Polypropylen
Boxfarbe	Schwarz
Spannung	12 V
Kapazität	70 Ah
Kälteprüfstrom	540 A/EN
L x B x H (mm)	261 x 175 x 225
Bodenleiste	B01
Schaltung	0
Anschlusspole	1
Gewicht	11.6 kg
Stück/Palette	48
Ausführung	trocken vorgeladen

**Bodenleiste B01**

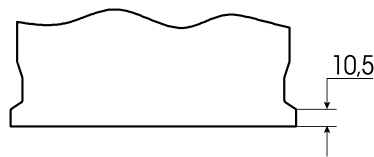
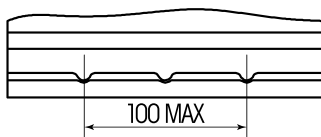

**Schaltung 0**

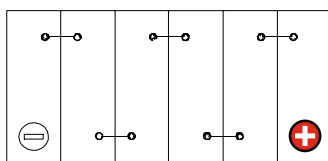

**Anschlusspole 1**

