

Art. Nr.: **545412040**

Bezeichnung: **54512**

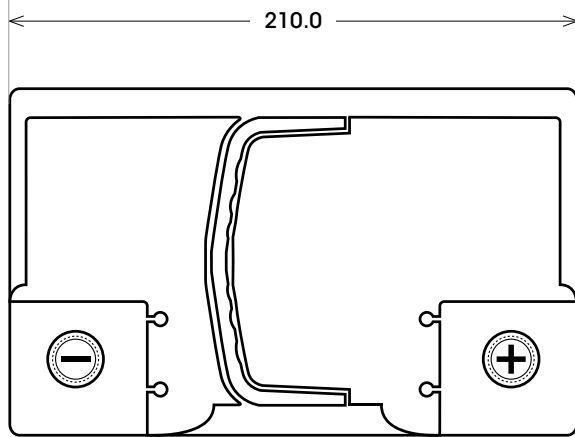
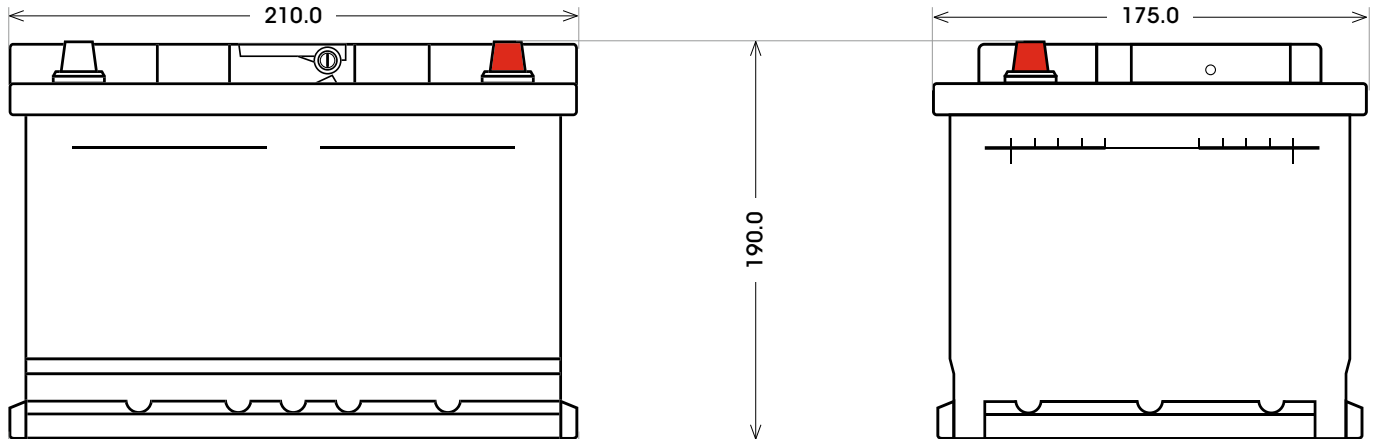

Technologie	Calcium-Calcium
Separator Typ	Envelope
Box-Material	Polypropylen
Boxfarbe	Schwarz
Spannung	12 V
Kapazität	45 Ah
Kälteprüfstrom	400 A/EN
L x B x H (mm)	210 x 175 x 190
Bodenleiste	B13
Schaltung	0
Anschlusspole	1
Gewicht	11.4 kg
Stück/Palette	72
Ausführung	G+G (gefüllt und geladen)

**Bodenleiste B13**

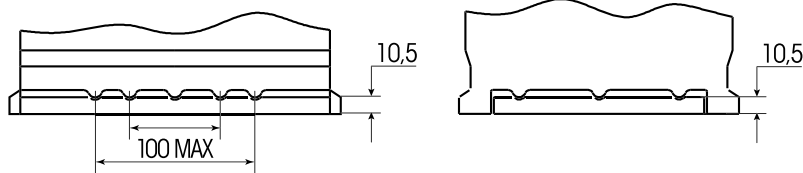

**Schaltung 0**

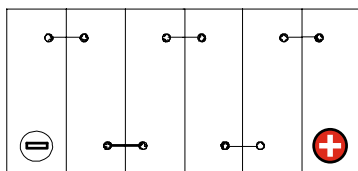

**Anschlusspole 1**

